



Bath Light

Installation Instructions

For
Bath Lights and Medicine Cabinets with Built-in Lights

See reverse side for Caution and Installation Notes

TOOLS AND SUPPLIES NEEDED

- ◆ Level
- ◆ Phillips Screwdriver

PARTS LIST

Ref.	Qty.	Item	Ref.	Qty.	Item
A	1	Electrical Box	I	1	Wood Front
B	1	Electrical supply ground wire	J	2	Cap Nuts (for mounting wood or brass cover)
C	3	Wire Nuts	K	2	1 3/4" Threaded Studs
D	*	Plastic Anchors	L	*	5" Threaded Studs
E	2	#8-32 X 5/8" Round Head Slotted Machine Screws	M	*	Thumbscrew**
F	1	Fixture Body			Globes**
G	*	Dry wall Screws			
H	1	Front Panel			

* Quantity varies according to width of light bar.
** Not included in some styles.

Figure 1

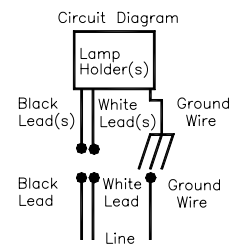
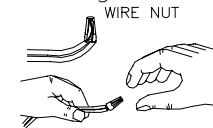

Figure 2



INSTALLATION STEPS

These instructions are for a Surface Mount installation. For Recessed Installation see Medicine Cabinet and Bath Light - Recessed Mount Installation Instructions.

1. Disconnect power at the main fuse box before installing the fixture.
2. Feed all fixture wires through large center hole in fixture crossbar. For recessed mounting, use knockout located in top of fixture body.
3. For circuit diagram see Figure 1. Place white fixture wire(s) evenly against white supply wire. Screw on wire nut connector. Pull gently on wire nut. If nut comes off - repeat above procedure. Wire nut should completely cover any exposed wire (see Figure 2).
4. Connect the black fixture wire(s) to black supply wire in the same manner.
5. Connect the green fixture ground wire to supply ground wire (if available) with wire nut (provided on some models only). If a supply ground wire is not available, attach green fixture ground wire to electrical box with ground screw and cupped washer. (These items are not supplied and would need to be purchased separately.)
6. Carefully position wires inside electrical box. Position fixture body so that the perforated holes in center of back are over electrical box. Secure fixture body to electrical box with two #8-32 X 5/8" screws through crossbar. Level fixture and secure permanently in place with plastic anchors and drywall screws.
7. Place front panel and wood front over fixture body. Secure with Cap Nuts (see Figure 3 for separate light installation or Figure 4 for installing a medicine cabinet with built-in light).
8. Secure globes (if your light fixture has globes) in cups with thumb screws.
9. Install light bulbs into sockets. Do not over-tighten light bulbs.
10. Reconnect electrical power at the main breaker or fuse box.

Figure 3

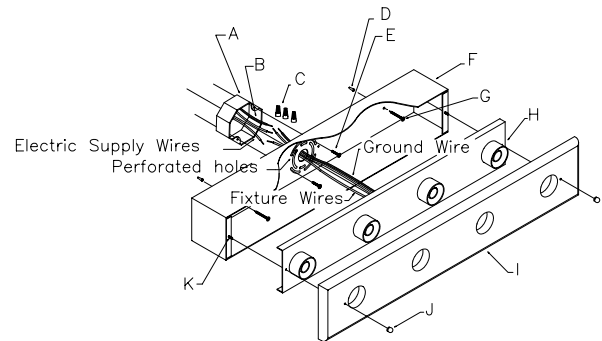

Figure 4

