



# Assemble & Install a 3-Piece Vanity

(With or without Optional Skirt)

Installation Instructions

See Manufacturer's instructions for Tops and Drop-In Bowls.

## Tools and Supplies

- Hammer & Center Punch
- Level
- Tape Measure
- Phillips (cross-tip) Screwdriver
- Power drill and 3/16" drill bit
- Saber Saw or Keyhole Saw
- Small Hammer (Skirt Option)
- Wire Cutters (Skirt Option)

## 3-Piece Vanity

1. Set the pieces beside each other as they will be assembled on a level surface.
2. Remove Drawers.  
Premier Drawers:
  - Squeeze orange handles underneath the Drawer.
  - Pull Drawer straight out, then up.
3. Remove doors on the sides closest to adjoining vanity.
  - Doors may be on the outer cabinets or the inner cabinet. The drawings show both styles.

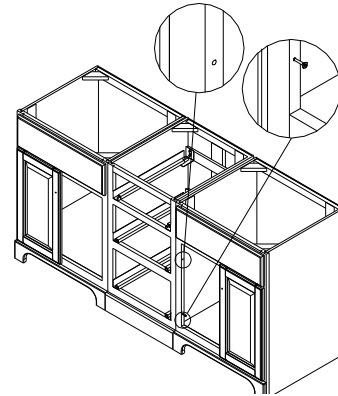

Two Bowl vanity

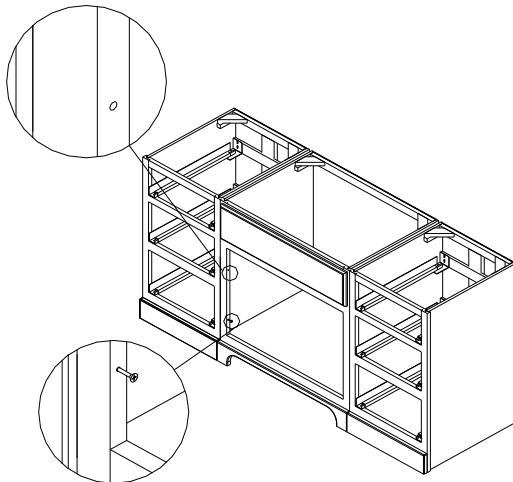

Single bowl vanity

4. Ensure the face frame is aligned with the next piece.
5. Drill holes through the face frames.
  - Gently clamp the face frames together before you drill the hole. Place soft rubber or wood between the clamp and the cabinet.
6. Secure the face frames to each other with the supplied screws.

7. Slide plywood spacers between the inner and outer cabinets at the back of the vanity.
8. Secure the vanity backs to each other with the supplied screws.
9. Cut plumbing holes into the back or base, as needed.
  - Use a Keyhole Saw or Saber Saw.
10. Install optional 1-piece skirt (See Page 3).

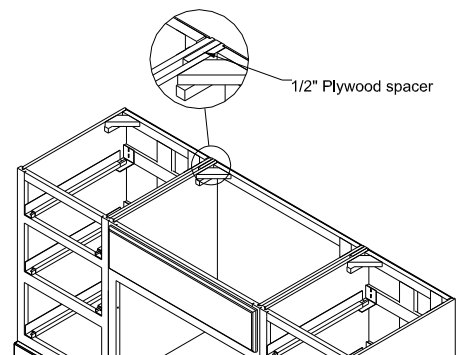

Single bowl vanity

11. Set vanity into its installation area.
  - Mark and cut the wall/floor molding, if needed, to assure a good fit and professional appearance.
12. Shim vanity until it's level.
  - Set a carpenter's level across the corners of the vanity

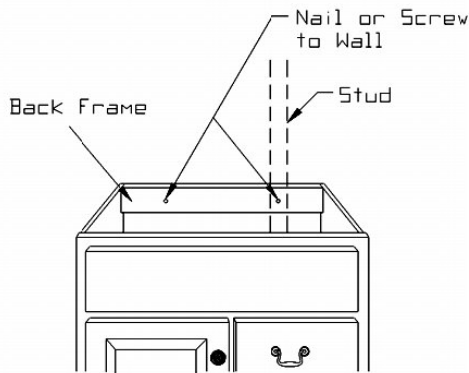
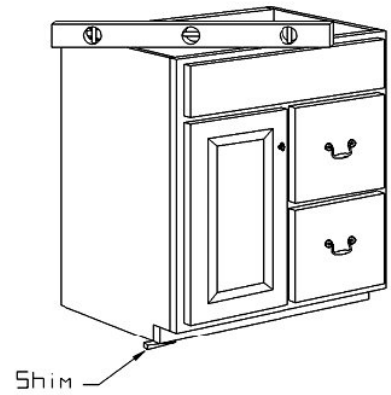

13. Drill Mounting Holes in Back Frame.
  - Locate Stud(s).
  - Drill a 3/16" hole through the back frame where it intersects with at least one Stud.
14. Drill mounting holes in the wall.
  - Masonry Walls: Set a lead anchor.
  - Ceramic Tile: Gently score surface with a hammer and center punch (or nail) then drill with a tungsten-carbide masonry drill bit. Never force the bit—allow it to cut.
15. Screw the vanity to the wall.

16. Replace Drawers.
17. Replace the doors
18. Install Door and Drawer hardware.
19. Install Top according to manufacturer's instructions.

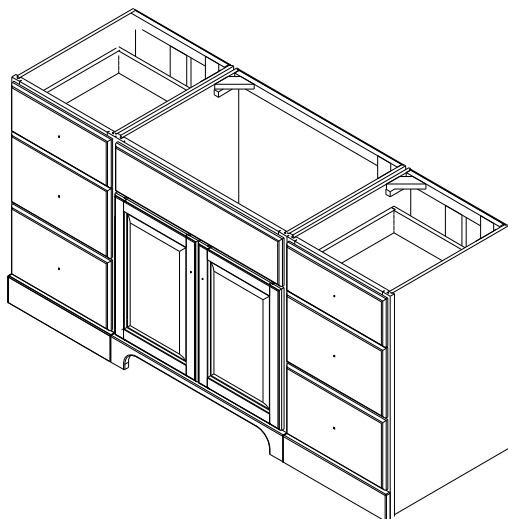

Assembled Single bowl Vanity

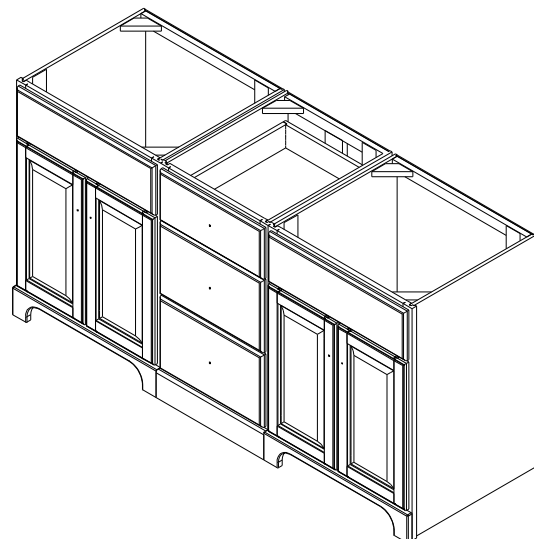

Assembled Two Bowl Vanity

## Optional Skirt

1. Turn the assembled vanity upside down.
2. Gently tap the back of the toe board toward the front of the cabinet.
  - This will loosen the toe board from the staples.
3. Cut the protruding staple ends with a pair of wire cutters.
  - Cut them as close to the block as possible.

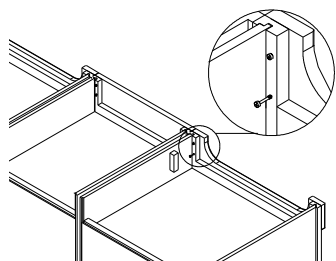
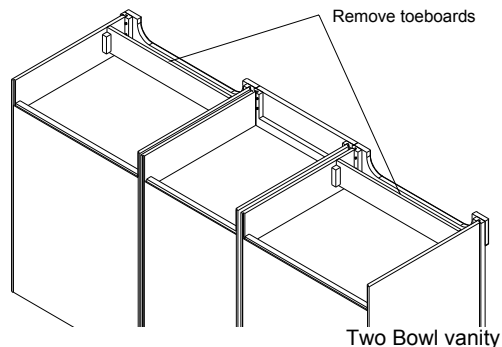

Two Bowl vanity

4. Remove the screws that hold the three skirts onto the cabinet.
  - Be sure to hold onto the skirt as you remove the screws. Failure to do so may damage your new cabinet.
  - Keep the screws—you'll need them to attach the optional skirt.

5. Align the optional skirt with the front or the assembled vanity.
6. Secure the outer ends of the skirt to the vanity assembly with the screws you kept in Step 4.
7. Secure the inside of the skirt to the vanity with the rest of the screws from Step 4.

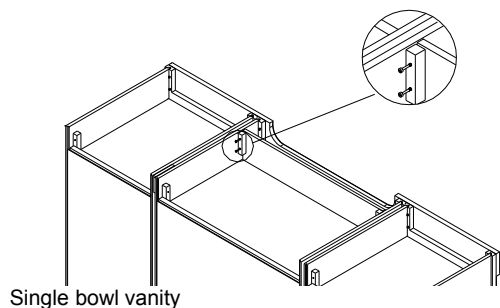
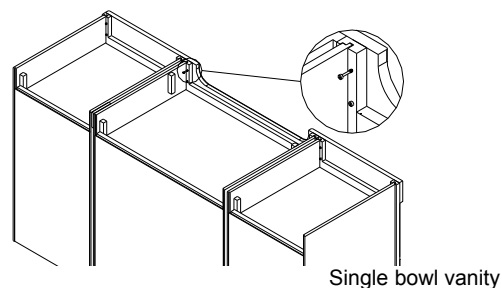

8. Screw the toe board(s) back into place.
9. Turn the cabinet right side up and continue with the installation procedure (Page 2).

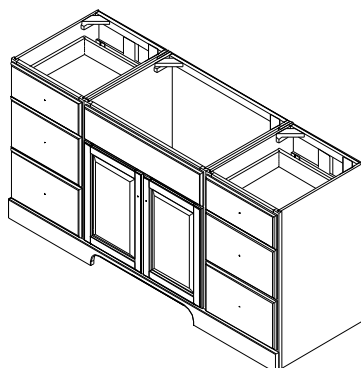

Single bowl vanity with Optional Skirt